

# SALES & ENGINEERING DATA

RATIO SERIES: **1:1**

FLUID P.S.I. RANGE: **20 - 120**

## 66615X-XXX-C THRU 66618X-XXX-C 1-1/2" METALLIC DIAPHRAGM PUMP

RELEASED: 1-10-97  
REVISED: 12-3-10  
(REV. 07) S-879

### DIMENSIONAL DATA

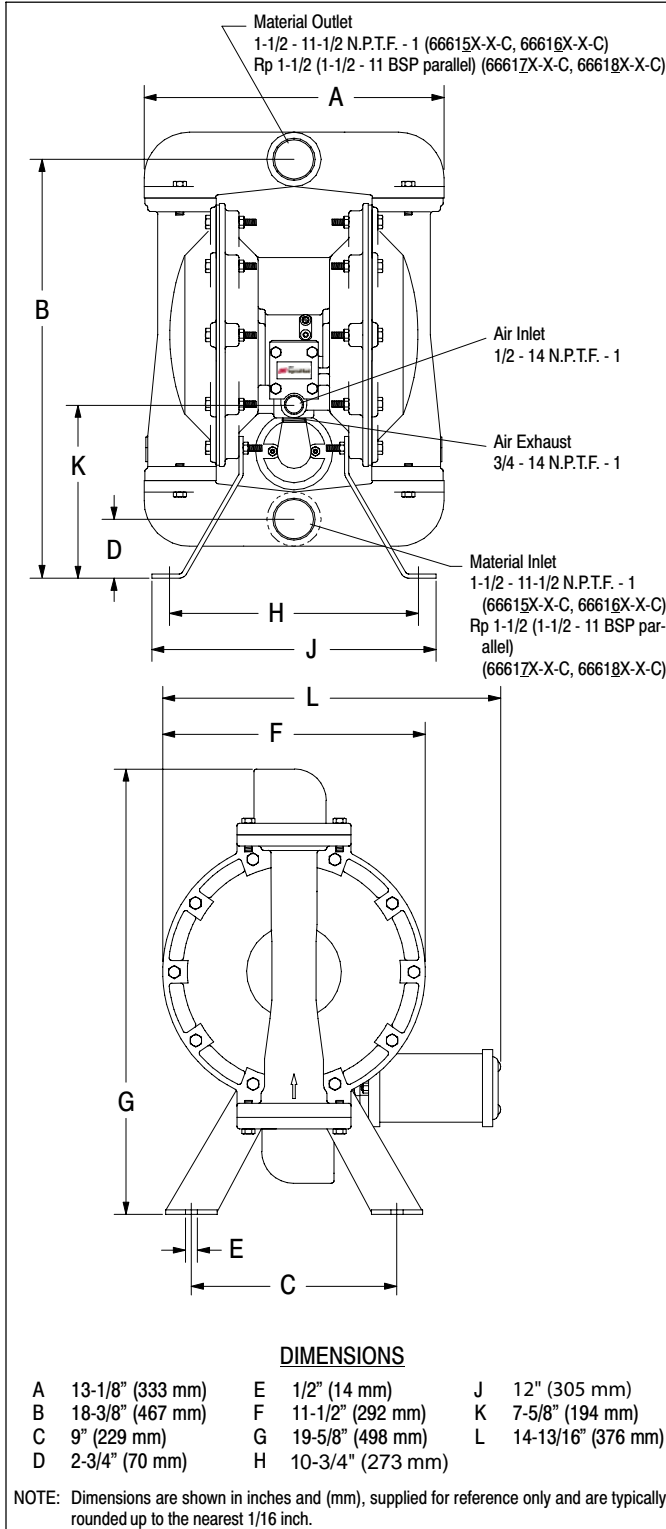

### SPECIFICATIONS

#### CONSTRUCTION

**Model Series** ..... 66615X-XXX-C thru 66618X-XXX-C  
**Pump Type** ..... Metallic, Air Operated, Double Diaphragm  
**Ratio** ..... 1:1  
**Material Inlet / Outlet (female)**  
 66615X-X-C and 66616X-X-C . . . 1-1/2 - 11-1/2 N.P.T.F. - 1  
 66617X-X-C and 66618X-X-C . . . Rp 1-1/2 (1-1/2 - 11 BSP parallel)  
**Air Inlet (female)** ..... 1/2 - 14 N.P.T.F. - 1  
**Air Exhaust (female)** ..... 3/4 - 14 N.P.T.F. - 1  
**Weight** Aluminum ..... 51.54 lbs (23.4 kgs)  
 Cast Iron ..... 79.54 lbs (36.1 kgs)  
 Stainless Steel ..... 84.54 lbs (38.3 kgs)  
 (add 23 lbs (10.4 kgs) for cast iron air motor section)  
**Air Section Service Kit** ..... 637118-C  
**Fluid Section Service Kit** ..... 637124-XX

**66615X - X X X - C**  
**637124 - X X X**

Diaphragm Material  
Ball Material

EXAMPLE: Model 666150-361-C  
Fluid Section Service Kit is 637124-61

#### PERFORMANCE

**Air Inlet Pressure Range** ..... 20 - 120 p.s.i. (1.4 - 8.3 bar)  
**Maximum Material Inlet Pressure** . . . 10 p.s.i. (0.69 bar)  
**Fluid Pressure Range** ..... 20 - 120 p.s.i. (1.4 - 8.3 bar)  
**Maximum Flow Rate (flooded inlet)** . . . . 90 g.p.m. (340.7 l.p.m.)  
**Maximum Particle Size** ..... 1/4" dia. (6.4 mm)  
**Maximum Temperature Limits (diaphragm / ball / seat material)**  
 Acetal ..... 10° to 180° F (-12° to 82° C)  
 E.P.R. .... -60° to 280° F (-51° to 138° C)  
 Hytrel ..... -20° to 150° F (-29° to 66° C)  
 Neoprene ..... 0° to 200° F (-18° to 93° C)  
 Nitrile ..... 10° to 180° F (-12° to 82° C)  
 Polypropylene ..... 35° to 150° F (2° to 66° C)  
 Polyurethane ..... 10° to 150° F (-12° to 66° C)  
 PVDF (Kynar) ..... 10° to 200° F (-12° to 93° C)  
 PTFE ..... 40° to 225° F (4° to 107° C)  
 Santoprene ..... -40° to 225° F (-40° to 107° C)  
 Viton ..... -40° to 350° F (-40° to 177° C)  
**Displacement / Cycle @ 100 p.s.i.** . . . 0.64 gal. (2.42 lit.)  
**Noise Level @ 70 p.s.i. - 60 c.p.m.**① . . . 77.7 db(A)②

① Tested with 93139 muffler installed.  
 ② The pump sound pressure level has been updated to an Equivalent Continuous Sound Level (L<sub>Aeq</sub>) to meet the intent of ANSI S1. 13-1971, CAGI-PNEUROPS S5.1 using four microphone locations.

#### ACCESSORIES:

- 65010 Neoprene "O" Ring Air Motor Kit
- 65764 Viton "O" Ring Air Motor Kit
- 66084-1 Air Line Connection Kit
- 637155 Abrasion Resistant Conversion Kit

### INGERSOLL RAND COMPANY LTD

209 NORTH MAIN STREET - BRYAN, OHIO 43506

① (800) 495-0276 • FAX(800) 892-6276

www.ingersollrandproducts.com

© 2010

CCN 15260219

# ARO

**IR** Ingersoll Rand  
Industrial Technologies

**PERFORMANCE CURVES**

**6661XX-XXX-C 1-1/2" METALLIC DIAPHRAGM PUMP**

